

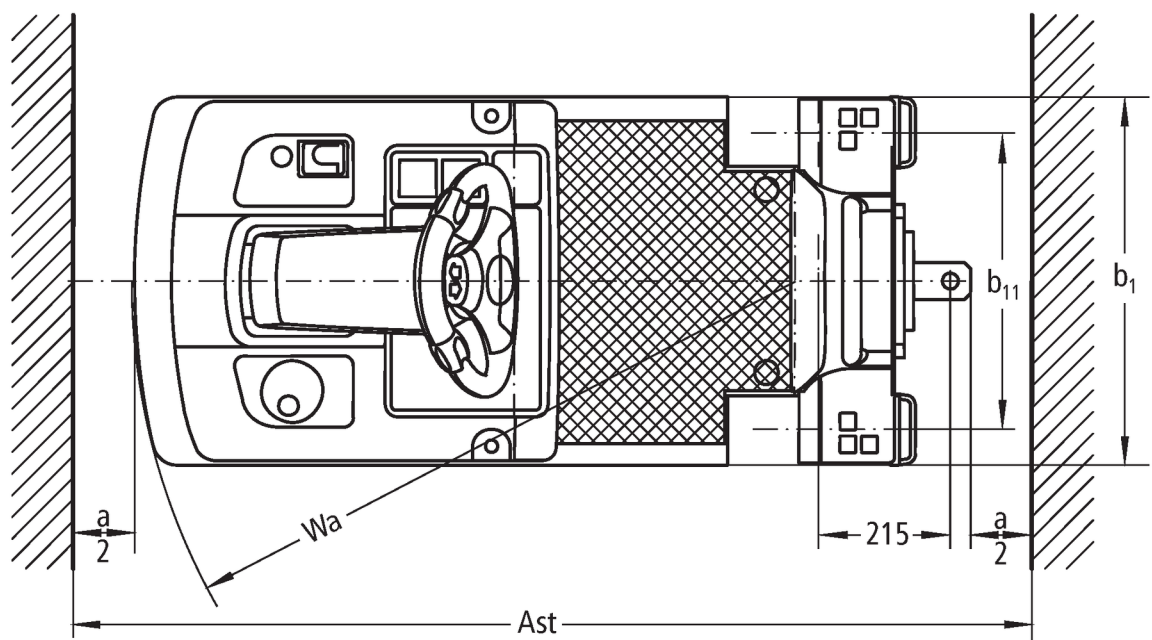

# Electric tow tractor **EZS 130**

Capacity: 3000 kg

# EZS 130

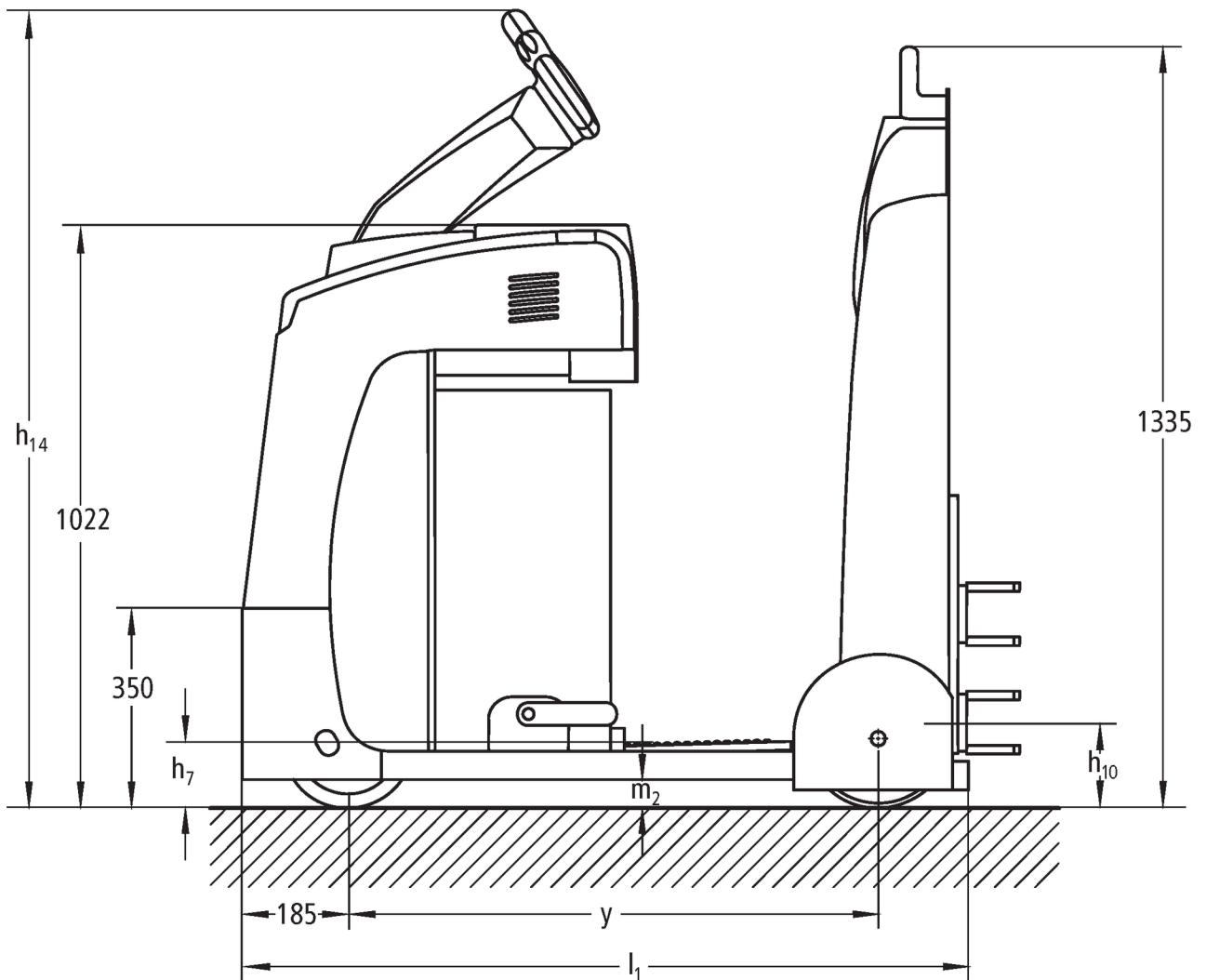

# EZS 130

Pulling ability

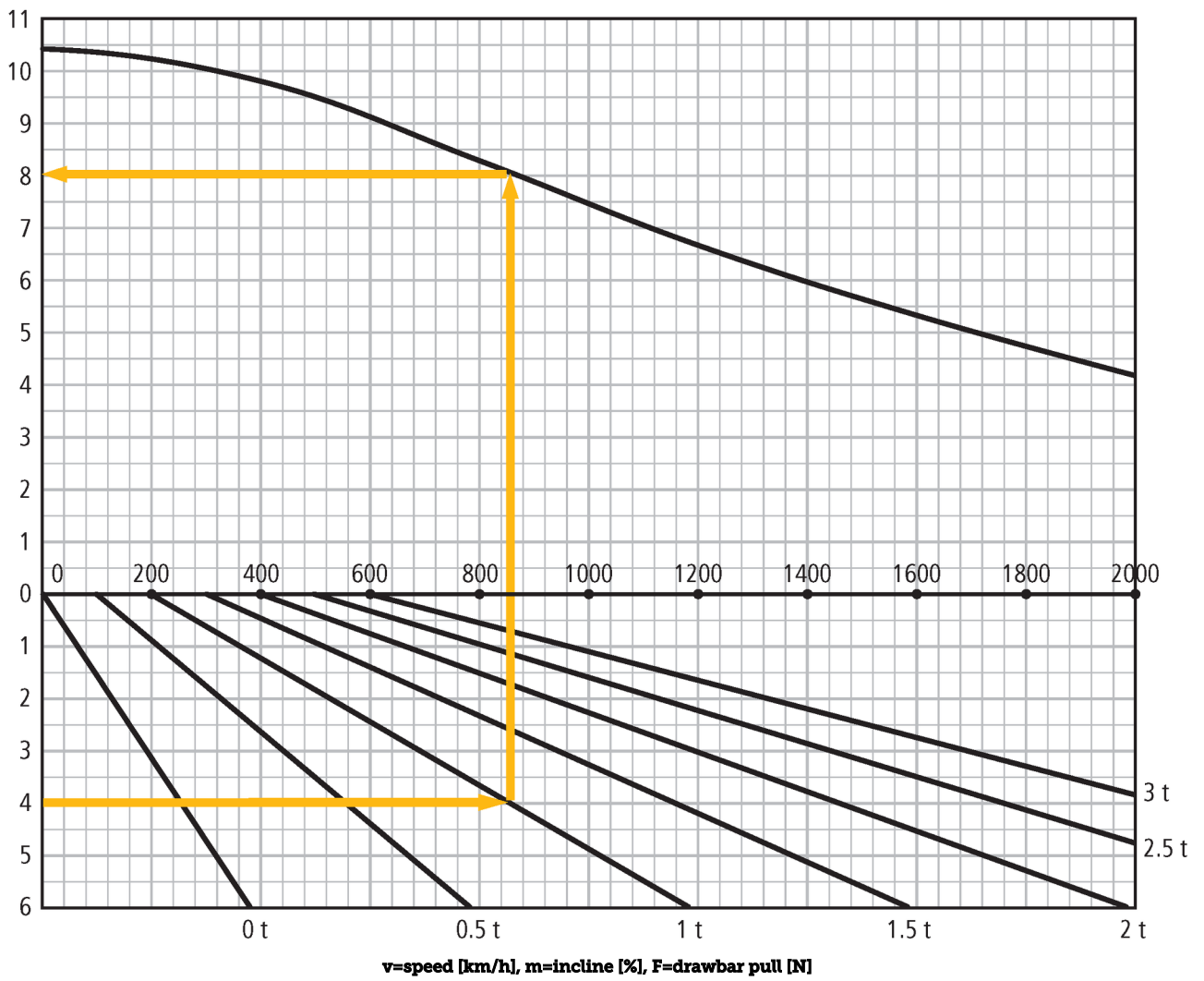

# VDI table

Stand-on: 10/2019

Characteristic	1.1	Manufacturer (abbreviated description)		Jungheinrich	
	1.2	Manufacturer's type designation		<b>EZS 130</b>	
	1.3	Drive		Electric	
	1.4	Operation		Stand-on	
	1.5	Capacity/load	Q	kg	3.000
	1.7	Rated drawbar pull		N	600
	1.9	Wheelbase	y	mm	930
Weights	2.1.1	Service weight (incl. battery)		kg	560
	2.3	Axle load unladen front/rear		kg	330 / 230
Wheels/suspension system	3.1	Tyres			Vulkollan, super-elastic
	3.2	Tyre size, front			Ø 230 x 78
	3.3	Tyre size, rear			Ø 250 x 80
	3.5	Wheels, number front/back (x=driven)			1x/2
	3.7	Tread width, rear	b <sub>11</sub>	mm	485
Basic dimensions	4.9	Height of tiller handle in drive position min./max.		mm	1.400 /
	4.12	Coupling height	h <sub>10</sub>	mm	158
	4.19	Overall length	l <sub>1</sub>	mm	1.275
	4.21	Overall width	b <sub>1</sub> /b <sub>2</sub>	mm	600
	4.32	Ground clearance centre of wheelbase	m <sub>2</sub>	mm	50
	4.35	Turning radius	W <sub>a</sub>	mm	1.080
Performance data	5.1	Travel speed laden/unladen		km/h	9 / 10.5
	5.5	Drawbar pull laden/unladen		N	600 /
	5.6	Max. drawbar pull laden/unladen		N	2.000 /
	5.10	Service brake			electromagnetic
E-motor/Electronics	6.1	Drive motor, performance S2 60 min		kW	2.8
	6.4	Battery voltage / nominal capacity		V / Ah	24 / 250
	6.5	Battery weight		kg	220
	6.6.1	Energy consumption according to EN cycle		kWh/h	0.82
	6.6.2	CO2 equivalent as per EN 16796		kg/h	0,44
Miscellaneous	8.1	Type of drive control			AC speedCONTROL
	10.7	Sound level as per EN12053, operator's ear		dB (A)	65

- In accordance with VDI Guideline 2198 this data sheet provides details of the standard truck only. Non-standard tyres, different masts, optional equipment, etc. may result in different values.

- 4.9: Height of jetPILOT - 4.12: other coupling heights available - 4.19: Overall length without coupling, as different coupling systems are available. - 5.1: see diagram - 5.5: Rated drawbar pull - 5.6: see diagram - 6.6: with rated load

The German production facilities in  
Norderstedt, Moosburg and Landsberg  
are certified.

ISO 9001  
ISO 14001

Jungheinrich fork lift trucks meet  
European safety requirements.



 **JUNGHEINRICH**

The logo features a red upward-pointing arrow integrated into the letter 'J' of the word 'JUNGHEINRICH', which is written in a bold, black, sans-serif font.